

Washing Sequence for Model AHLVW-240

- 1st WASH COMPRESSED AIR
- 2nd WASH RE-CIRCULATED DM WATER — DRAIN
- 3rd WASH RE-CIRCULATED DM WATER
- 4th WASH COMPRESSED AIR
- 5th WASH FRESH DM WATER — COLLECT IN TANK
- 6th WASH COMPRESSED AIR
- 7th WASH FRESH DM WATER
- 8th WASH COMPRESSED AIR
- 9th WASH SILICON / FRESH DM WATER — COLLECT IN TANK
- 10th WASH COMPRESSED AIR

Brothers

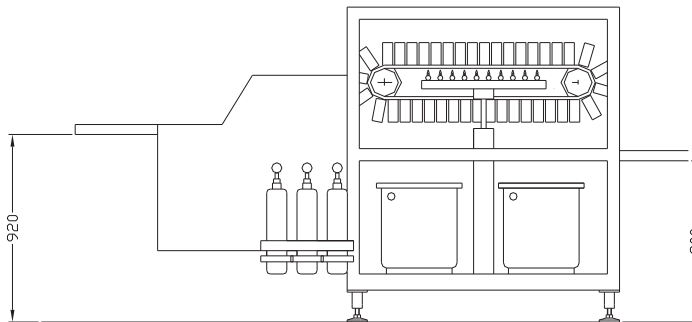
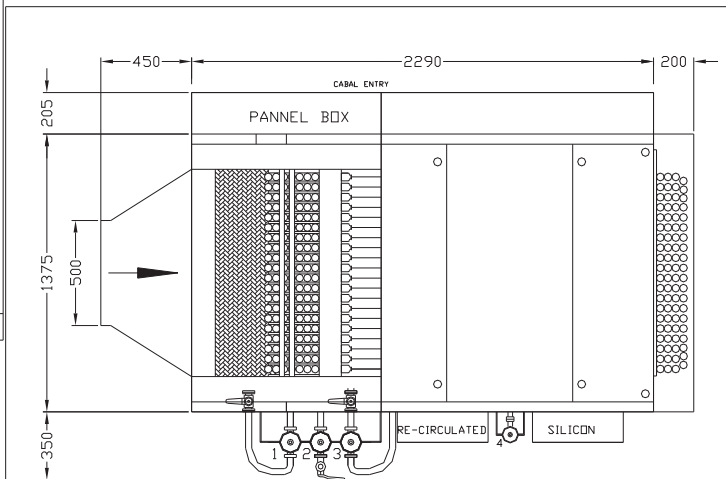

Right of technical improvements and modifications reserved.
All illustrations and dimensions are shown for information only



M/C MODEL AHLVW-240
Automatic Linear Tunnel type Vial Washing Machine with speed of 240 Vials per minute