

TOP PRESSING

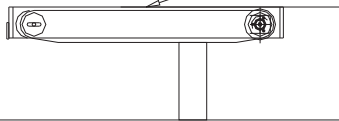

CONVEYOR

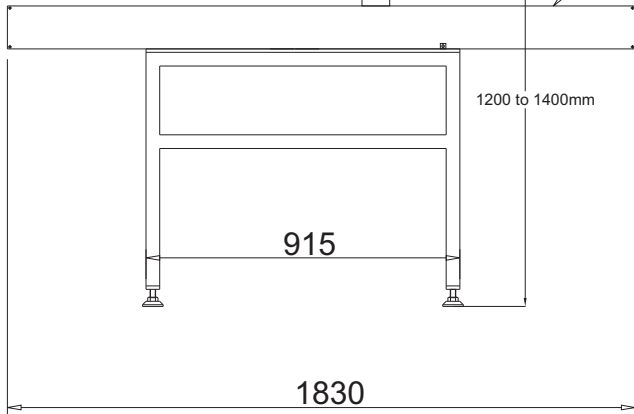

Dimensions in MM

Right of technical improvements and modifications reserved.
All illustrations and dimensions are shown for information only



BROTHERS
PHARNAMACH INDIA PVT. LTD.
brothers@usa.net

M/C MODEL **EFL-60F** Single Side Flat Bottle Labelling Machine

SPEED : Max. 100 BPM DEPENDING ON Bottle size and label size

D.NO.

P.NO.